

## GENERAL INFORMATION

**TM-613** three-phase 24-Hour/7-Day Time Switch can be operated in 380Vac power supplies, such as three-phase exhaust fan, HVACR, OEM applications, agricultural facilities, and other 3 phase devices. It has one volt-free changeover contact.



This Digital Timer is accurate to the minute, designed with **17 ON/OFF(event) per day**. Rechargeable battery is for retaining the current time and the program setting during Timer's operating power disconnected.

Also, it provides 15-combination of Daily-Programs which can leads great convenience to users upon choosing desired DAYS of WEEK

## TECHNICAL DATA

Power supply: 350V~420V AC, 50/60Hz  
 Hysteresis: 2 sec/day (25°C)  
 ON/OFF operation: 17 ON/OFF  
 Power consumption: 2VA(MAX)  
 Output control: 16A 380VAC  
 Service life: Mechanical  $10^7$ , Electrical  $10^7$   
 Minimum interval: 1 minute  
 Switching contact: 1 changeover switch  
 Power reserve: 3 years (Lithium battery)  
 Ambient temperature: -25~+50°C  
 Ambient humidity: 35~85%RH  
 Dimensions: 120\*105\*52mm

## WIRING DIAGRAM

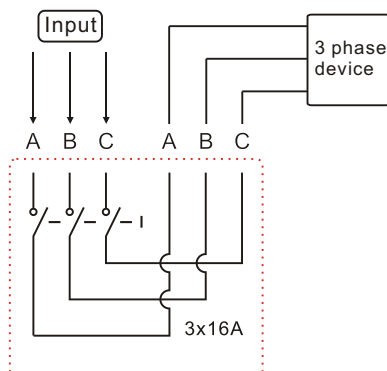
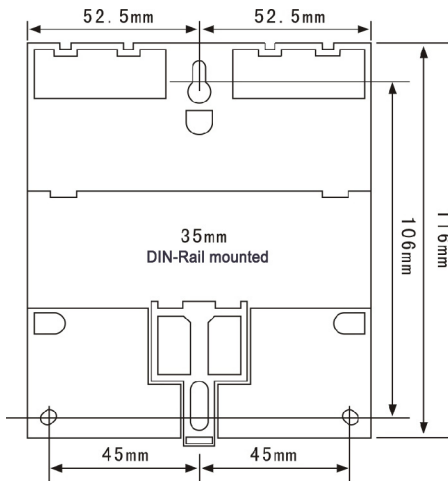

## PROGRAMMING THE TIMER

### A. Functional description to buttons on panel

1. **Ⓟ**: Programs review & setting programs
2. **MANUAL**: To select "ON, AUTO or OFF"
3. **⌚**: To adjust current DAY and TIME
4. **D+**: To adjust day of week
5. **H+**: To adjust Hour
6. **M+**: To adjust minute
7. **RESET**: Reset Timer's setting
8. **LED**: To indicate ON/OFF status

Press **RESET** button to reset Timer before programming

### B. Adjusting CLOCK

Press and hold **⌚** and then press **D+** key, **H+** key, **M+** key respectively to adjust clock of Timer to accurate **DATE, HOUR, MINUTE**. LCD screen shall indicate 0:00~23:59

### C. Start to programming the TIMER

1. Press **Ⓟ** key. LCD screen shall show ON 1 - - : - - -
2. Press **D+** key to select any of 15-combination of Daily-Programs to your application demand. Continuing to press **D+** key, LCD shall alternating indicate among 15-combinations.
3. Press **H+**, **M+** respectively to set desired Hour and Minute for **ON 1**
4. After finished setting of **ON 1**, Press **Ⓟ** key again, OFF 1 - - : - - - shall appear on LCD screen.
5. Press **D+** key to select any of 15-combination of Daily-Programs to your application demand. Continuing to press **D+** key, LCD shall alternating indicate among 15-combinations.

**Day-combination chosen in each of ON/OFF program-period must be consistent**

6. Repeat Programming procedure "3" to set desired Hour & Minute for **OFF 1**
7. When finished setting **ON 1** & **OFF 1**, Press **Ⓟ** ON 2 - - : - - - shall appear on LCD screen.
8. Repeat programming procedure above to complete rest of ON/OFF program-period(event)
 

ON 1 - - : - - - ⇒ OFF 2 - - : - - - ⇒ ●●●●●● OFF 17 - - : - - -

or just to the desired number of ON/OFF(event) setting for demand of practicable application.

ON 1 - - : - - - ⇒ OFF 1 - - : - - - ⇒ ON 2 - - : - - - ●●●●●● OFF 5 - - : - - -
9. When finished program-setting(event), press **⌚**, Timer shall start to execute programs.

### D. To review programs

Keep to press **Ⓟ**, display on LCD screen shall alternating display among each of 17 ON/OFF

## CAUTION

Remark:

1. The connection and installation of electrical devices may only be carried out by a qualified electrician.
2. For voltage and electrical RATING information, please refer to the markings on the back of timer.
3. See the back of timer for proper wire connections.
4. Timer may need to be connected to power source in order to set the program.
5. Press RESET key before first use to clear memory.
6. Do not immerse timer in water or any other liquid.